

Revisi		Revisi		Revisi		Revisi		Revisi		Revisi	
Area	Rev.	Descrizione	Data	Approvata							
	1	RILASCIO PROGETTO	13/02/2018	R.A.							

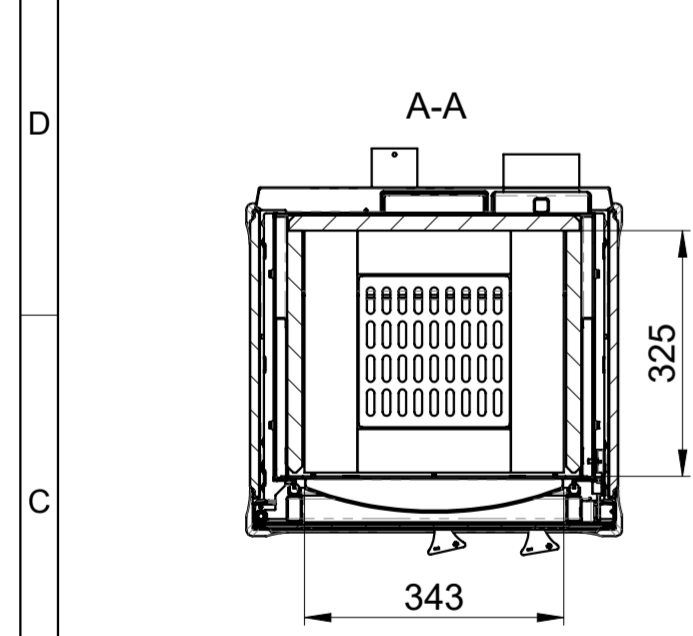

VISTA SEZIONE CAMERA COMBUSTIONE

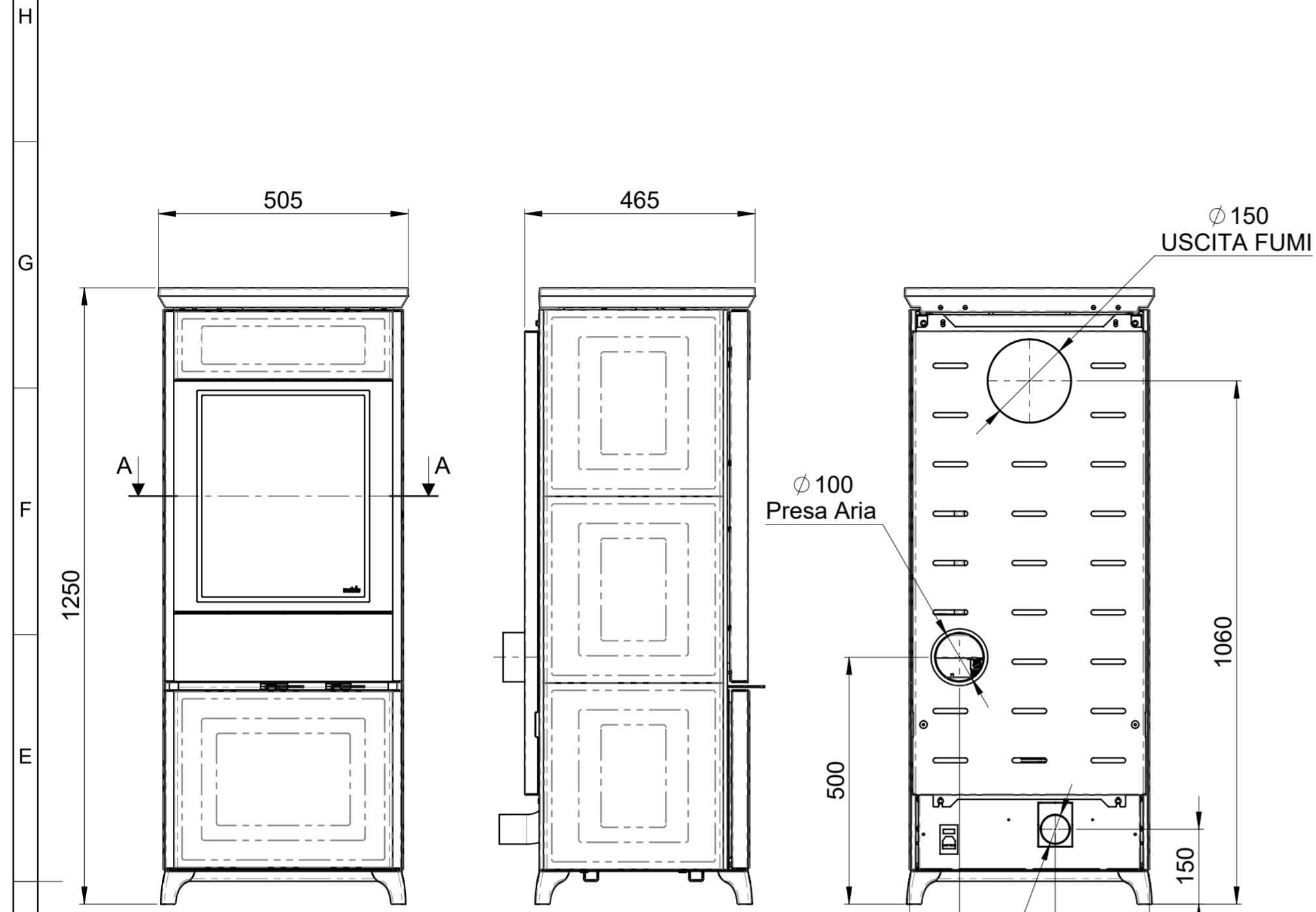
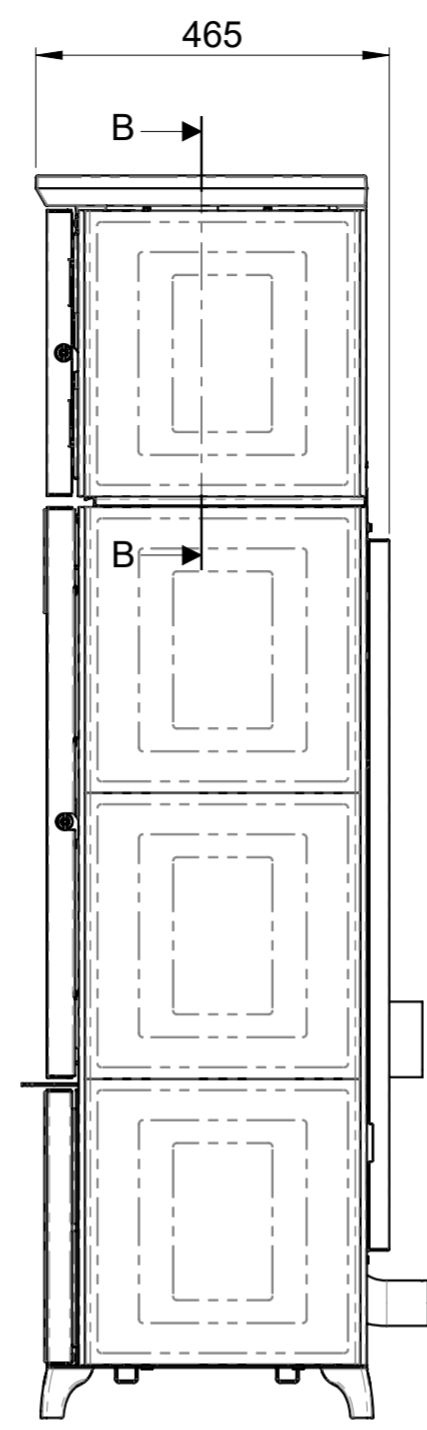
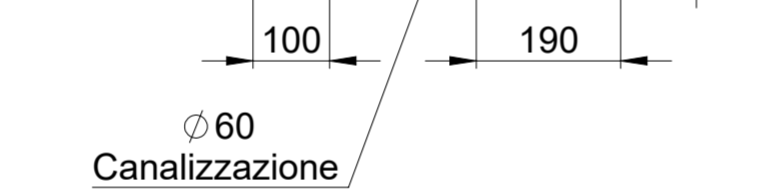
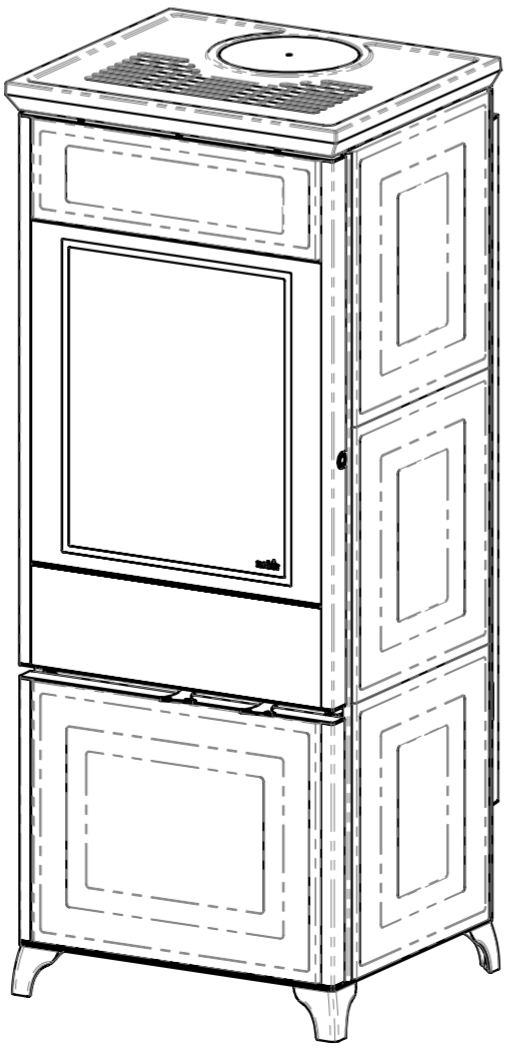
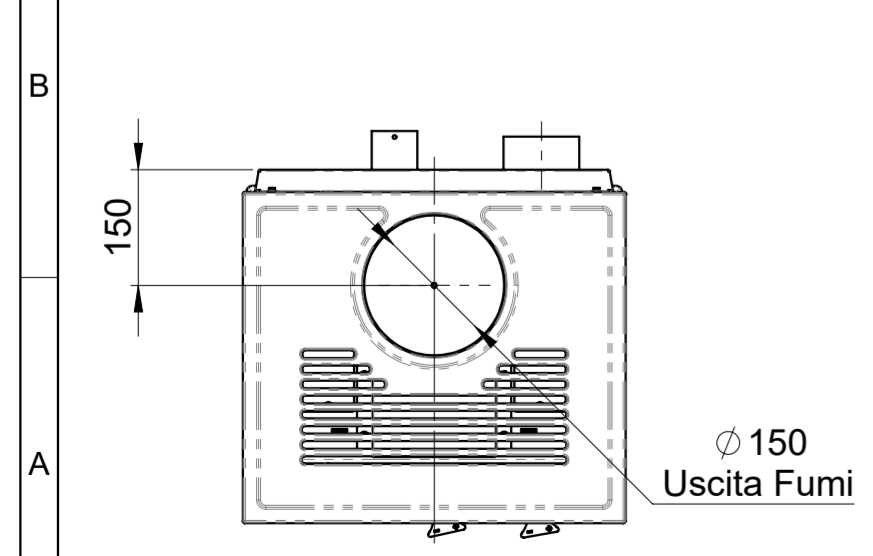

VERSIONE FORNO (Vista Laterale)

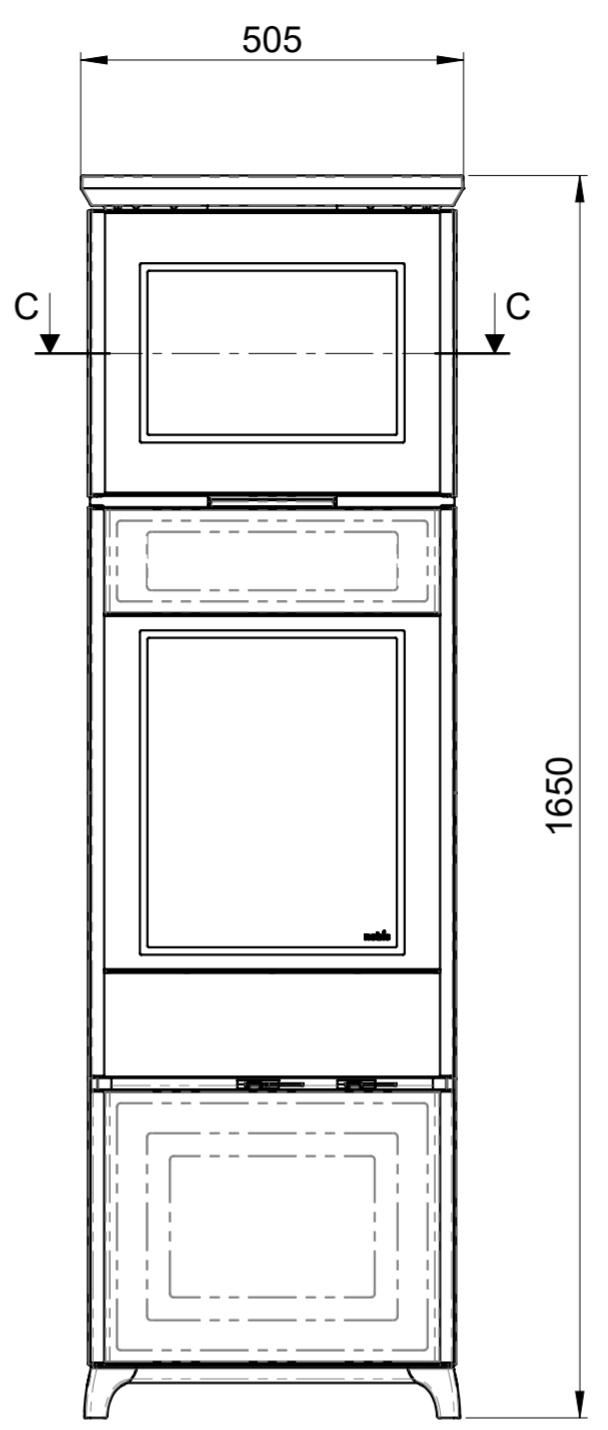

VERSIONE FORNO (Vista Frontale)

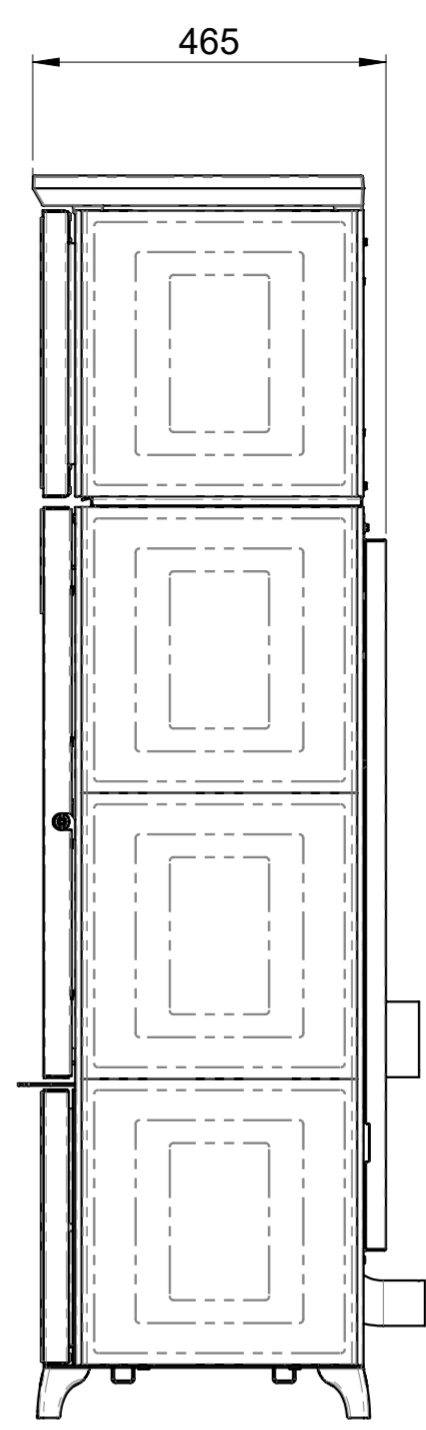

VERSIONE ACCUMULO (Vista Laterale)

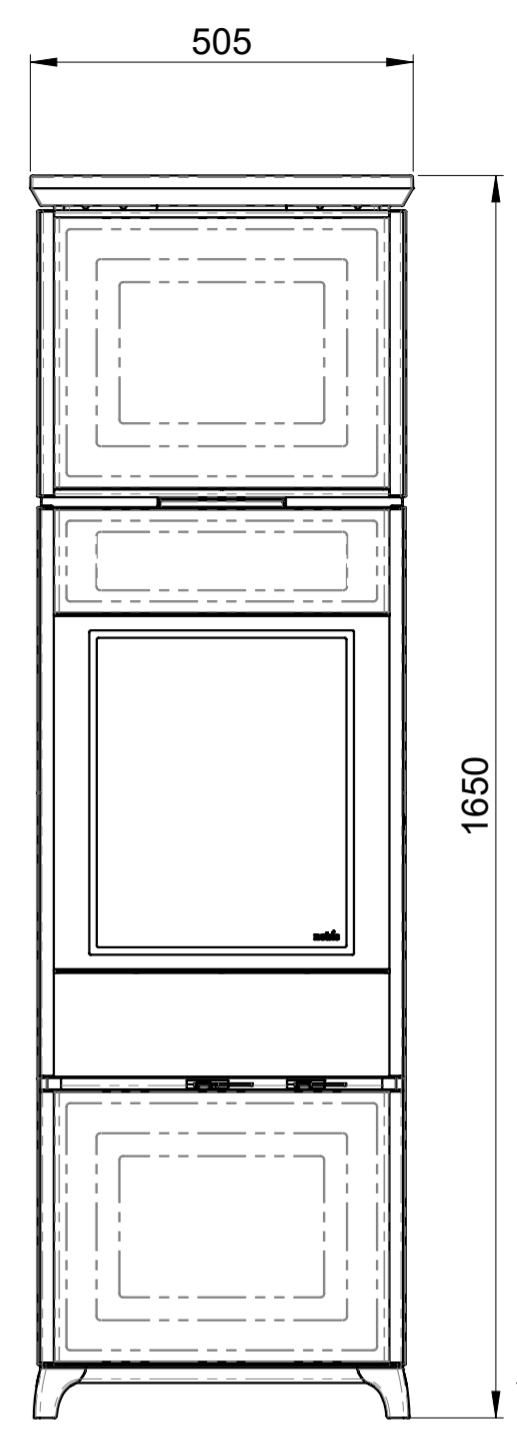

VERSIONE ACCUMULO (Vista Frontale)

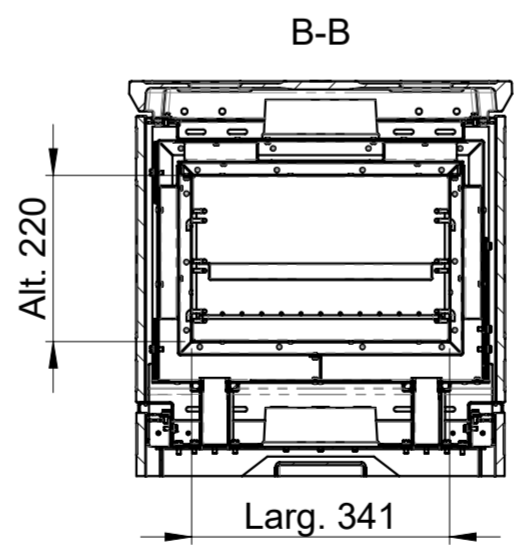

VISTE SEZIONE FORNO

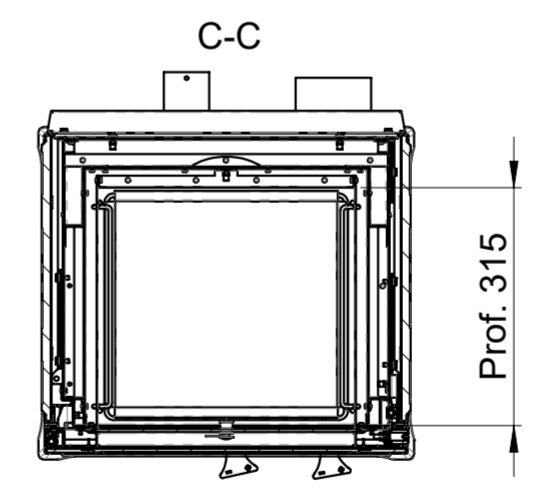

TUTTI GLI SVILUPPI FORNITI IN FORMATO DXF SONO TEORICI. IL PARTICOLARE REALIZZATO DEVE ESSERE CONFORME AL DISEGNO 2D/3D. ALL FLAT PATTERNS PROVIDED IN DXF FORMAT ARE THEORETICAL. THE PIECE MUST BE IN COMPLIANCE WITH THE 2D/3D DRAWING.

TOLLERANZE GENERALI SECONDO LA CLASSE UNI EN 22768-mK GENERAL TOLERANCES AS PER UNI EN 22768-mK	SCALA (SCALE) 1:6	FORMATO (FORMAT) A2	MATRICE (MATRIX) -	MATERIA PRIMA (RAW MATERIAL) -
DENOMINAZIONE (DENOMINATION) ASSIEME MODELLO CLASSIC 200	MATERIALE (MATERIAL) -			
	TRATTAMENTO SUPERFICIALE (SURFACE TREATMENT) -			
CODICE FORNITORE (SUPPLIER CODE) -	DATA (DATE) 07/03/2023	DISEGNATORE (DESIGNER) R.A.	CONTR. (CHECKED) E.B.	PESO Kg. (WEIGHT) 180.48
NOBIS S.r.l. Via Palazzetto 11 22037 Portogallo - BS - Italy P.Iva e Cod. Fisc. 04222670160	N. DISEGNO (DRAWING) N0077-SLAN-E1_T		STATO (STATUS) S	REVISIONE (REVISION) 2